

HD48... SERIES, HD 49... SERIES



HD48...SERIES, HD49...SERIES PASSIVE OR ACTIVE TRANSMITTERS - TEMPERATURE, RELATIVE HUMIDITY AND TEMPERATURE, DEW POINT AND TEMPERATURE

HD48... and HD49... series of transmitters measure temperature, relative humidity and the dew point temperature.

Versions with only standard analog output or with only RS485 output with MODBUS- RTU protocol are available. The models with analog output provide a signal suitable for transmission to a remote display, recorder or PLC. The models with RS485 output are suitable for connection to a PC or PLC.

The models of the HD48... series are active transmitters and accept both direct and 24Vac alternating power supply; they have standard current (4...20 mA) or voltage (0...10V) outputs, or a serial RS485 output, depending on the model. The models of the HD49... series are passive transmitters and thus suitable to be inserted in a 4...20 mA current loop.

Both series of transmitters are designed for temperature and humidity control in conditioning and ventilation applications (HVAC/BEMS) in the following sectors: pharmacy, museums, clean rooms, ventilation ducts, industrial and civil sectors, crowded places, canteens, auditoria, gyms, high-density farms, greenhouses, etc.

The transmitters measure relative humidity with a well proven temperature compensated capacitive sensor that assures precise and reliable measurements in the course of time. Both HD48... and HD49... series are available in two probe temperature ranges: standard -20...+80 °C and extended -40...+150 °C for the most critical applications.

A stainless steel 10 µm filter protects the sensors against dust and particles (other filters are available for different applications).

The transmitters are factory calibrated and no further adjustments are required.

Each series is available in different versions:

- with horizontal probe for duct mounting (HD48...TO..., HD49...TO...),
- with vertical probe for wall mounting (HD48...TV..., HD49...TV...);
- with remote probe connected to the transmitter by means of a cable (HD48...TC..., HD49...TC...). Cable lengths available are 2, 5 and 10m.

The probes can be supplied in two different lengths: 135 mm or 335 mm.

Various accessories are available for the installation: for example to fix the probe to the duct, it can be used the HD9008.31 flange, a 3/8" universal biconical connection or a PG16 metal cable gland (Ø10...14mm). A 4-digit optional display ("L" model) allows to display the measured parameters in a continuous or sequential mode.

Technical specifications		
	STANDARD RANGE	EXTENDED RANGE
Relative Humidity		
Sensor	Capacitive	
Measuring range	0...100% RH	
Accuracy @T=15...35°C	±1.5% RH (0...90% RH), ±2.0% RH (90...100% RH)	
Accuracy @ rest of T range	±(1.5+1.5% of the measure) % RH	
Repeatability	0.4% RH	
Sensor working temperature	-20...+80 °C	-40...+150 °C
Temperature		
Measuring range	-20...+80 °C	-40...+150 °C
Sensor	NTC 10kΩ	Pt100 class A
Accuracy	±0.3 °C (0...+70 °C) ±0.4°C (-20...0 °C, +70...+80 °C)	±0.3°C
Repeatability	0.05°C	0.05°C
Dew Point		
Sensor	Parameter calculated from relative humidity and temperature	
Measuring range	-20...+80 °C DP	
Accuracy	See table 1	
Repeatability	0.5°C DP	
Type of output (according to the model)		
HD4807T...	Temperature	4...20 mA (-20...+80 °C), $R_L < 500\Omega$ 22 mA outside the measuring range
HD4807ET...	Temperature	4...20 mA (-40...+150 °C), $R_L < 500\Omega$ 22 mA outside the measuring range
HD48V07T...	Temperature	0...10 Vdc (-20...+80 °C), $R_L > 10k\Omega$ 11 Vdc outside the measuring range
HD48V07ET...	Temperature	0...10 Vdc (-40...+150 °C), $R_L > 10k\Omega$ 11 Vdc outside the measuring range
HD48S07T... HD48S07ET...	Temperature	Only RS485 with MODBUS-RTU protocol
HD4907T...	Temperature	4...20 mA (-20...+80 °C), $R_{Lmax} = (Vdc-12)/0.022$ 22 mA outside the measuring range
Models HD4907ET...	Temperature	4...20 mA (-40...+150 °C), $R_{Lmax} = (Vdc-12)/0.022$ 22 mA outside the measuring range
HD4817T...	Relative Humidity	4...20 mA (0...100% RH), $R_L < 500\Omega$ 22 mA outside the measuring range
	Temperature	4...20 mA (-20...+80 °C), $R_L < 500\Omega$ 22 mA outside the measuring range
HD4817ET...	Relative Humidity	4...20 mA (0...100% RH), $R_L < 500\Omega$ 22 mA outside the measuring range
	Temperature	4...20 mA (-40...+150 °C), $R_L < 500\Omega$ 22 mA outside the measuring range

HD48V17T...	Relative Humidity	11 Vdc outside the measuring range
	Temperature	0...10 Vdc (-20...+80 °C), $R_L > 10k\Omega$ 11 Vdc outside the measuring range
HD48V17ET...	Relative Humidity	0...10 Vdc (0...100% RH), $R_L > 10k\Omega$ 11 Vdc outside the measuring range
	Temperature	0...10 Vdc (-40...+150 °C), $R_L > 10k\Omega$ 11 Vdc outside the measuring range
HD48S17T... HD48S17ET	Relative Humidity	Only RS485 with MODBUS-RTU protocol
	Temperature	
HD4917T...	Relative Humidity	4...20 mA (0...100% RH), $R_{Lmax} = (Vdc-12)/0.022$ 22 mA outside the measuring range
	Temperature	4...20 mA (-20...+80 °C), $R_{Lmax} = (Vdc-12)/0.022$ 22 mA outside the measuring range
HD4917ET...	Relative Humidity	4...20 mA (0...100% RH), $R_{Lmax} = (Vdc-12)/0.022$ 22 mA outside the measuring range
	Temperature	4...20 mA (-40...+150 °C), $R_{Lmax} = (Vdc-12)/0.022$ 22 mA outside the measuring range
HD4877T...	Dew Point	4...20 mA (-20...+80 °C DP), $R_L < 500\Omega$ 22 mA outside the measuring range
	Temperature	4...20 mA (-20...+80 °C), $R_L < 500\Omega$ 22 mA outside the measuring range
HD48V77T...	Dew Point	0...10 Vdc (-20...+80 °C DP), $R_L > 10k\Omega$ 11 Vdc outside the measuring range
	Temperature	0...10 Vdc (-20...+80 °C), $R_L > 10k\Omega$ 11V dc outside the measuring range
HD48S77T...	Dew Point	Only RS485 with MODBUS-RTU protocol
	Temperature	
HD4977T...	Dew Point	4...20 mA (-20...+80 °C DP), $R_{Lmax} = (Vdc-12)/0.022$ 22 mA outside the measuring range
	Temperature	4...20 mA (-20...+80 °C), $R_{Lmax} = (Vdc-12)/0.022$ 22mA outside the measuring range

Table 1 - Accuracy of dew point measurement:

		°C DP										
		-20	-10	0	10	20	30	40	60	80		
Temperature °C	-20	≤±1										
	-10	≤±1	≤±1									
	0	≤±1	≤±1	≤±1								
	10	≤±3	≤±1	≤±1	≤±1							
	20	≤±4	≤±2	≤±1	≤±1	≤±1						
	30		≤±3	≤±1,5	≤±1	≤±1	≤±1					
	40				≤±2	≤±1	≤±1	≤±1				
	60					≤±5	≤±2,5	≤±2	≤±1	≤±1		
80							≤±4	≤±2	≤±1	≤±1		

Installation notes

To fix the probe inside a ventilation duct, a pipe, etc., use for example the HD9008.31 flange, a PG16 metal cable gland (Ø10...14mm) or a 3/8" universal biconical connection.

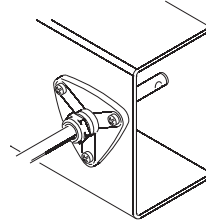

HD9008.31 Flange

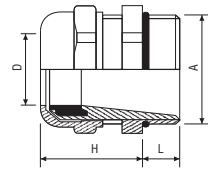

PG16 metal cable gland
D = 10...14mm
L = 6.5mm
H = 23mm
A = PG16

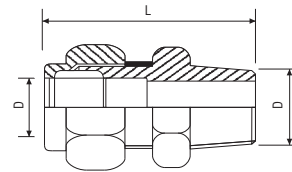

Universal biconical connector
L = 35mm
D = 14mm
A = 3/8"

Power supply and electrical connections		
	HD48...	HD49...
Power supply	18...40 Vdc or 24 Vac ±10%	12...40 Vdc
Consumption	- 4 mA@24V(models with voltage output) - 4 mA@24V with open output, 20 mA@24V with 12 mA output (models with current output) - 2 mA@24V models with serial RS485 output	
Electrical connections	Screw type terminal block, max 1,5mm ² , M16 cable gland for input cable	
General characteristics		
Standard filter	PBT and 10 µm stainless steel grid protection (P8), 20 µm PTFE (P7) only for extended range	
TV probe working temperature	-20...+80 °C	
...TO...TC Probes working temperature	STANDARD RANGE	EXTENDED RANGE
	-20...+80 °C	-40...+150 °C
Electronics working temperature	-20...+60 °C	
Storage temperature	-20...+80 °C	
Electronics protection class	IP66	
Materials	ABS, polycarbonate	
Weight	from approx. 120 gr. (TV) to approx. 900 gr. (TC2.10)	
Case dimensions	80x84x44 (length x width x height)	

Electrical connections

HD48... series with analog output

Power the instrument as shown in the below connection schemes, the power supply terminals are marked as +Vcc and GND. Depending on the model, the output signal is available between:

- Ta and AGND terminals for the transmitters of the HD4807T...and HD48V07T... series.
- RH% and AGND, Ta and AGND terminals for the transmitters of the HD4817T... and HD48V17T... series.
- DP and AGND, Ta and AGND terminals for the transmitters of the HD4877T... and HD48V77T... series.

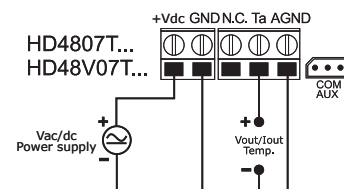
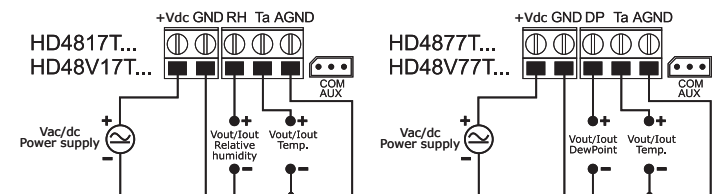

HD48...series with RS485 output

Connect the instrument as shown in the below connection schemes, the power supply terminals are marked as +Vcc and GND.

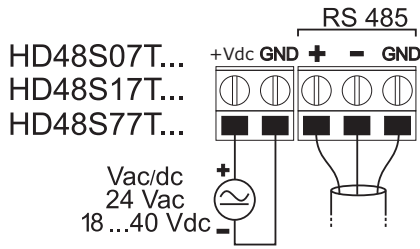

Thanks to RS485 output, several instruments can be connected to form a network. The instruments are connected in a sequence through a shielded cable with twisted pair for signals and a third wire for the ground.

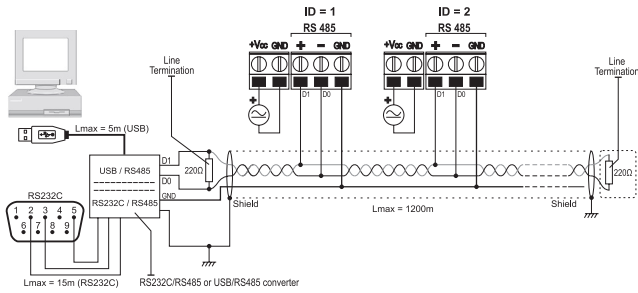

Line termination must be set at the two network ends. To polarize the line during nontransmission periods, resistor are connected between signal and power supply lines. The maximum number of devices that can be connected to the (Bus) line RS485 depends on the load characteristics of the devices to be connected.

The standard RS485 requires that the total load does not exceed 32 Unit Loads. The load of a HD48S... transmitter is equal to ¼ of the unit load.

If the total load is more than 32 unit loads, divide the net in segments and insert a signal repeater between one segment and the next one. At the beginning and at the end of each segment a line termination must be connected.

The instrument has a built in line termination that can be connected or removed through a short jumper placed next to the terminal block. If the instrument is the last or the first device of a network group, connect the termination placing the short jumper between the "RT" and "240 ohm" indications. If the instrument is not at the end of a network group, remove the termination placing the short jumper between the "RT" and "OPEN" indications.

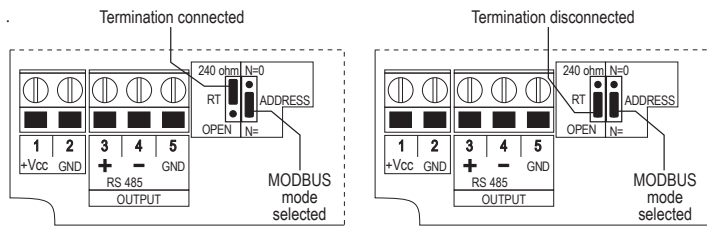

The cable shield must be connected to both line ends. The cable should have the following features:

- Characteristic impedance: 120 ohm
- Capacity: less than 50pF/m
- Resistance: less than 100 ohm/km
- gauge: 0,22 mm² (AWG24) at least.

The cable maximum length depends on baud rate and cable characteristics. Typically, the maximum length is 1200m. The data line must be kept separated from any power lines in order to prevent interferences on the transmitted signal. For connection to a PC, a RS232C/RS485 or a USB/RS485 converter must be used. To operate with the MODBUS-RTU protocol be sure that the ADDRESS short jumper is between "ADDRESS" and "N=" indications.

Each transmitter of the network is univocally identified by an address. The address must be between 1 and 247. There must not be any other transmitters connected with the same address. The address must be configured before connecting the instrument to the network. To set the instrument address use

the software HD48STCAL downloadable from Delta OHM website and the RS48 cable with built in USB/RS485 adapter. To configure the instrument it is necessary to move the ADDRESS short jumper between the "ADDRESS" and "N=0" indications to select the setup mode. After the configuration, move the short jumper back between the "ADDRESS" and "N=" indications.

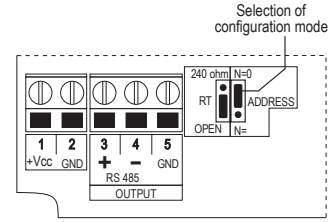

In MODBUS mode it is possible to read the measured values by the instrument through the 04h functioning code (Read Input Registers). Table 2 represents the available quantities with its relative register address.

Table 2 – MODBUS Registers

Address	Quantities	Format
0	Temperature in °C (x10)	16-bit integer
1	Temperature in °F (x10)	16-bit integer
2	Relative Humidity in % (x10)	16-bit integer
3	Dew Point in °C (x10)	16-bit integer
4	Dew Point in °F (x10)	16-bit integer
5	State register Bit 0 = 1 => temperature measure in error Bit 1 = 1 => relative humidity measure in error Bit 2 = 1 => dew point temperature calculation in error Bit 3 = 1 => error in data configuration	16-bit integer

HD49... series

Follow the connection schemes shown below, the maximum load resistance that can be connected to each 4...20 mA output depends on the power supply Vcc applied, according to the relation:

$$R_{Lmax} = (Vdc - 12) / 0.022, \text{ e.g. if } Vdc = 24Vdc \text{ the max load is } R_{Lmax} = 545 \text{ ohm.}$$

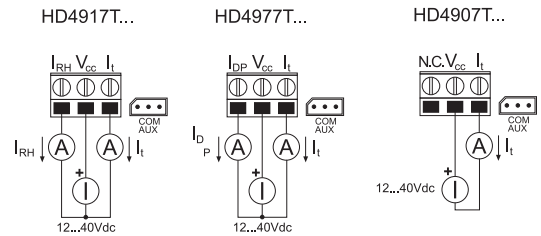

Relative humidity probe calibration

The HD48... and HD49... transmitters are supplied factory calibrated and ready to use. If necessary, it is possible to calibrate the relative humidity sensor using the saturated salt solutions HD75 (75% RH saturated salt solution) and HD33 (33% RH saturated salt solution) by connecting the instrument to the PC and using the HD48TCAL software.

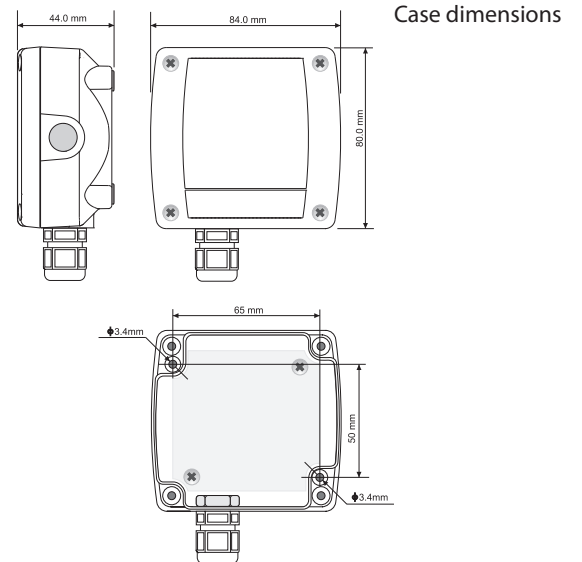

Probe dimensions
TO series

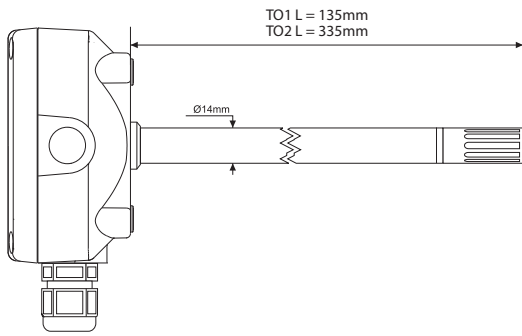

TC series

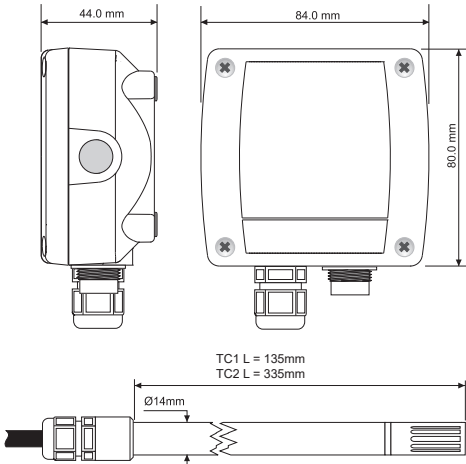

TV series

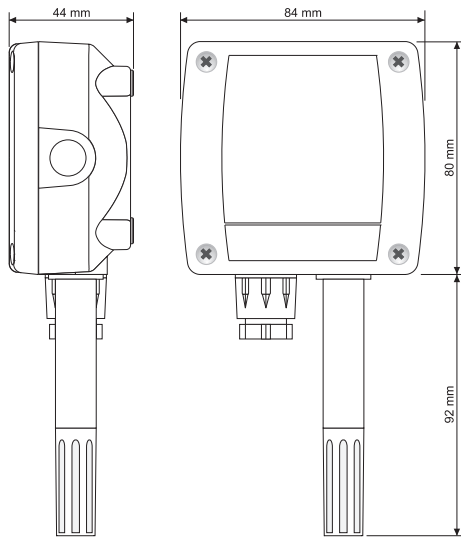

ORDERING CODES:

HD48
HD49

Blank = without display
L = with LCD display

Cable length (only for TC models)
2 = 2m
5 = 5m
10 = 10m

Probe type
TO1 = 135mm
TO2 = 335mm
TC1 = 135mm
TC2 = 335mm
TV = vertical wall mounting

Blank = standard range -20...+80 °C
E = extended range -40...+150 °C (models TV excluded)

07 = temperature output
17 = Temperature and % RH outputs
77 = Temperature and dew point outputs

Blank = 4...20 mA analog output
V = 0...10 Vdc analog output (only HD48... models)
S = only RS485 output with MODBUS-RTU protocol (only HD48... models)
Note: models with analog output have an output for each measured quantity.

SOME EXEMPLES OF ORDERING CODES

HD4807TV: Wall mounting digital active temperature transmitter.

Temperature range: -20...+80 °C.

Analog output: 4...20 mA (-20...+80 °C).

Probe working range -20...+80 °C. Power supply 18...40 Vdc or 24Vac.

HD4917TO1: Digital passive (current loop) temperature and relative humidity transmitter for duct mounting. AISI304 steel probe, diameter 14mm and stem length 135mm,

Relative humidity range 0...100% RH, temperature range -20...+80 °C.

Analog outputs: 4...20 mA (0...100% RH) for RH and 4...20 mA (-20...+80 °C) for temperature. Probe working range -20...+80 °C. Power supply 12...40 Vdc.

HD4817TC25L: Digital active temperature and relative humidity transmitter with LCD display. AISI304 steel probe, diameter 14mm and stem length 335mm, with 5m cable.

Relative humidity range 0...100% RH, temperature range -20...+80 °C.

Analog outputs: 4...20 mA (0...100% RH) for RH and 4...20 mA (-20...+80 °C) for temperature. Probe working range -20...+80 °C. Power supply 18...40 Vdc or 24Vac.

HD48V17ETC25: Digital active temperature and relative humidity transmitter, extended range. AISI304 steel probe, diameter 14mm and stem length 335mm, with 5m cable.

Relative humidity range 0...100% RH, temperature range -40...+150 °C.

Analog outputs: 0...10V (0...100% RH) for RH and 0...10V (-40...+150 °C) for temperature. Probe working range -40...+150 °C. Power supply 18...40 Vdc or 24Vac.

HD48S17TC25L: Digital active temperature and relative humidity transmitter with LCD display. AISI304 steel probe, diameter 14mm and stem length 335mm, with 5m cable.

Relative humidity range 0...100% RH, temperature range -20...+80 °C.

Only RS485 output with MODBUS-RTU protocol. Probe temperature working range -20...+80 °C. Power supply 18...40 Vdc or 24Vac.

Accessories

RS48: Cable for RS485 serial connection with built-in USB/RS485 converter.

CP27: Connection/converter cable from COM AUX serial port to USB.

HD75: 75% RH saturated solution for the verification of the relative humidity sensor, complete of screw adaptors for probes with Ø 14mm and Ø 26mm.

HD33: 33% RH saturated solution for the verification of the relative humidity sensor, complete of screw adaptors with Ø 14mm and Ø 26mm.

HD9008.31: Wall flange with cable gland to fix Ø 14mm probes.

Protection for humidity probes Ø 14, thread M12x1

P6: 10µm sintered stainless steel protection. Operating temperature: -40...180 °C.

P7: 20µm PTFE protection. Operating temperature: -40...150 °C.

P8: PBT and 10µm stainless steel grid protection. Operating temperature: -40...120 °C.